



PROWALRUS™

Surgical Technique Guide
Spinal Connectors
Hook System



www.prodorth.com



contents

02
04

Surgical Technique of Prodorth
Hook Fixation System

Indications/Contraindications

Secondary and Possible Side
Effects

05
06

PROWALRUS™ - Size

Prodorth Hook Fixation
System Instruments

07
08

SURGICAL PROCEDURE
PEDICLE HOOK

Step 1
Surgical Preparation

Step 2
Hook Side Preparation

Step 3
Pedicle Hooks Insertion

08

SURGICAL PROCEDURE
LAMINAR HOOKS

Step 1
Surgical Preparation

Step 2
Hook Side Preparation

Step 3
Laminar Hooks Insertion

Step 4
Selection of the Appropriate
Size of Rod

Step 5
Rod Bending

Step 6
Insertion of Setscrews



PROWALRUS™

SURGICAL TECHNIQUE OF THE PRODORTH HOOK FIXATION SYSTEM

Prodorth has developed this surgical technique document for surgeons and healthcare professionals but not for unauthorized persons. This document is a supportive source but not a complete instruction for an inexperienced surgeon to perform the entire surgery, therefore the information within this surgical technique should be considered with the previous medical experiences and education of the surgeon. Surgeon's medical judgement and decisions will be the best treatment for the patient and the results will be different according to the patient's physical and mental situation.

DEVICE DESCRIPTION

Prodorth Hook Fixation System implants play an important role in helping to achieve fixation during posterior spinal fusion in patients who are risen due to degenerative disc disease (DDD), traumas, or any disorders on the spine.

Hook Fixation System implants are long-term implants, however, they are not able to withstand the forces like healthy bone structures.

The raw material used for the Prodorth Hook Fixation System is Titanium alloy (ASTM F 136 / ISO 5832-3)

Current Status of the Device: The device is already CE marked (since 2019) and has been on the market.

HOOK GMDN No: 65115

Product Class: Annex II of Directive 93/42/EEC) Class IIb

Raw Materials: Ti6Al4V-ELI (ASTM F 136 / ISO 5832-3)

Biological Assessment:

Biological Assessment of Device
According to TS EN ISO 10993-1 : 2021

Category	Implant Device
Contact Level	Bone / Tissue
Contact Duration	C (Permanent - > 30 days)

STERILIZATION

Prodorth Hook Fixation System is released to market as non-sterile. They must be sterilized prior to surgical use. All packaging materials are removed prior to sterilization. The recommended sterilization method for Prodorth Hook Fixation System implant is steam sterilization in an autoclave. The products which are intended to be sterilized should remain in an autoclave at 134 °C for 18 minutes. There is no other sterilization method Prodorth recommends.

INTENDED PURPOSE OF THE DEVICE

Prodorth Hook Fixation System is a long-term implant in order to provide the performance of the spinal fixation system as anchors for the rods. Hook system can help to achieve stability and temporary fixation during Posterior Fixation in patients with spinal deformities.

- It is a single-use device
- Does not include human or animal tissue and phthalate
- Does not include any software or accessory
- The product is supplied as non-sterile
- Product does not cause any radioactive source or beam diffusing

Population: Skeletally mature male / female patients

Intended User(s): Healthcare professionals (Surgeons trained and experienced in the related field.)

INDICATIONS

The specific indications of the Prodorth Hook Fixation System are as follows:

- Degeneration of the disc
- Idiopathic Scoliosis
- Deformities of the spine relating to kyphosis
- Paralytic scoliosis and oblique status of the pelvis
- Instability of deformity
- Deformities of the spine
- Oblique status of the pelvis and neuromuscular scoliosis
- Vertebral fracture or dislocation
- Tumors
- Spondylolisthesis
- Stenosis
- Pseudoarthrosis
- Nonunion of the bone
- Trauma (i.e., fracture or dislocation)
- Failed previous fusion

Note: The application area of the Prodorth Hook Fixation System is the cervical and thoracolumbar spine.

CONTRAINDICATIONS

Prodorth Hook Fixation System should never be used in any condition not described in the indications for use. Contraindications include, but are not limited to:

- Infection history; systemic, spine or localized
- Obesity
- Mental diseases
- Alcohol or drug addiction
- Fever or unusual increase in the amount of leukocyte
- Local inflammation, with or without fever or leukocytosis
- Pregnancy
- Allergic reaction against implant materials
- Serious osteoporosis, osteopenia
- Open wounds

- Congenital abnormality, suspicious spine anatomy, tumor or any condition, which is affecting dependable implant fixation or shortening the life cycle of the device,
- Any kind of condition regarding anatomical structures or physiological performance; including the insufficiency of tissues around the surgical area
- Patients who are not obeying precautions or who are not able to
- An unhealthy shape (deformity) of the vertebrae at the level of the surgery
- Damaged vertebrae from an accident (trauma) at the level of the surgery
- Uncooperative patient or patient with neurologic disorders rendering the patient incapable of following instructions

These contraindications can be relative or absolute and should be considered when physician makes a decision. The above list does not include all possibilities. Surgeons should discuss relative contraindications with the patient.

SECONDARY AND POSSIBLE SIDE EFFECTS

The patient shall be notified regarding the below mentioned adverse events pre-operatively. A second surgical treatment may be required:

- Bending, loosening or fracture of implants or instruments
- Tissue or nerve damage caused by improper positioning and placement of implants or instruments
- Allergic reactions to metal including possible tumor formation
- Skin or muscle sensitivity in patients with insufficient tissue
- Nonunion or delayed union of the bone
- Infection
- Nervous or vascular damages because of surgical trauma, including loss of neurological functions, paralysis and leakage of spine fluid
- Gastrointestinal, urological or systemic disorders
- Pain or illness
- Herniated nucleus pulposus, disc disruption or degeneration at, above, or below the level of surgery
- Bone loss above or below surgical limit
- Bleeding blood vessels
- Wrong alignment of anatomical structures; including loss of spine slope, reduction and/or height loss,
- Bursitis
- Pain in the area of bone transplantation
- Inability to perform daily activities
- Prolongation of the operation time due to malfunction of some instruments during the operation
- Death

WARNINGS

- Never re-use an implant even in a perfect state. Any Implant which has been used, twisted, bent, implanted, and then removed even if it appears intact, must be discarded
- Use new implants routinely
- Similar products of competitors shall not be combined with the components of the Prodorth Hook Fixation System. Prodorth implants and instruments should only be used with Prodorth instruments. In case of using other companies' instruments, this might result in galvanic corrosion, and incompatibility between the products as well
- No component of the Prodorth Hook Fixation System shall be reused
- The restricted shelf life of the device is 10 years. It should never be used after its expiration date
- Correct selection of the implant is highly important!

Several Hook implants are available and can be used depending on the different anatomical sites and the required needs:

PROWALRUS™



Laminar Narrow Blade



Laminar Wide Blade



Pedicular

CERVICAL

SIZE	REF.CODE
Narrow Blade - Small	151.01 0017N-CS
Narrow Blade - Medium	151.01 0017N-CM
Narrow Blade - Large	151.01 0017N-CL
Wide Blade - Small	151.01 0017W-CS
Wide Blade - Medium	151.01 0017W-CM
Wide Blade - Large	151.01 0017W-CL
Pedicular - Small	151.01 0018-CS
Pedicular - Medium	151.01 0018-CM
Pedicular - Large	151.01 0018-CL

THORACOLUMBAR

SIZE	REF.CODE
Narrow Blade - Small	151.01 0017N-S
Narrow Blade - Medium	151.01 0017N-M
Narrow Blade - Large	151.01 0017N-L
Wide Blade - Small	151.01 0017W-S
Wide Blade - Medium	151.01 0017W-M
Wide Blade - Large	151.01 0017W-L
Pedicular - Small	151.01 0018-S
Pedicular - Medium	151.01 0018-M
Pedicular - Large	151.01 0018-L

PRODORTH HOOK FIXATION SYSTEM INSTRUMENTS

Prodorth offers different designs of instruments for each step of the surgical procedure. They have been designed as simply as possible and user-friendly in order to provide ease of use. Prodorth instruments are made of stainless chrome nickel steel, aluminum, and silicone.



▶▶▶ Hook Inserter 1 PH 500.10.001



▶▶▶ Hook Inserter 2 PH 500.10.002



▶▶▶ Hook Elevator 2 PH 500.10.003



HOOK INSERTER 1	PH 500.10.001
HOOK INSERTER 2	PH 500.10.002
HOOK ELEVATOR 1	PH 500.10.003
HOOK ELEVATOR 2	PH 500.10.004
HOOK ELEVATOR 3	PH 500.10.005
HOOK ELEVATOR 4	PH 500.10.006
HOOK IMPLANT CASE	PH 500.10.007
CONTAINER HOOK	PH 500.10.008
FORCEPS HOOK HOLDER (Upon Request)	PH 500.10.009

SURGICAL PROCEDURE PEDICLE HOOK

The pedicle hook is designed bifurcated at the bottom to engage the pedicle at that level and is always placed up-going position (Figure 1)

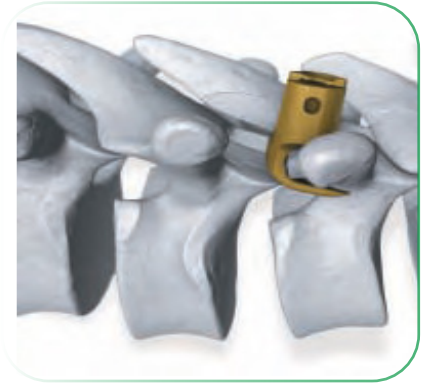

Figure 1

Step 1 Surgical Preparation

The patient is usually positioned prone on a spinal table. The general essentials of posterior spinal fusion surgery are applied. (Figure 2)



Figure 2

Step 2 Hook Side Preparation

The HOOK ELEVATOR 1 (PH 500.10.003) is used for hook site preparation. To ease the insertion of the pedicle elevator safely, a partial inferior facet excision may be performed. The mallet can be gently used with a pedicle elevator to make a path for the pedicle hook. (Figure 3)



Figure 3



Step 3

Pedicle Hooks Insertion

Once the pedicle is confirmed to be well prepared, the appropriate-sized pedicle hook is introduced with Hook Inserter 1 (PH 500.10.001) and placed in the required position with help of Hook Inserter 2 (PH 500.10.002) to facilitate the placement. (Figure 4)



Figure 4

The hook is inserted towards the inferior pedicle while paying attention to direct the hook medial or ventral towards the spinal canal. The hook should be placed in a stable position within the residual facet joint strongly against the pedicle. (Figure 5)

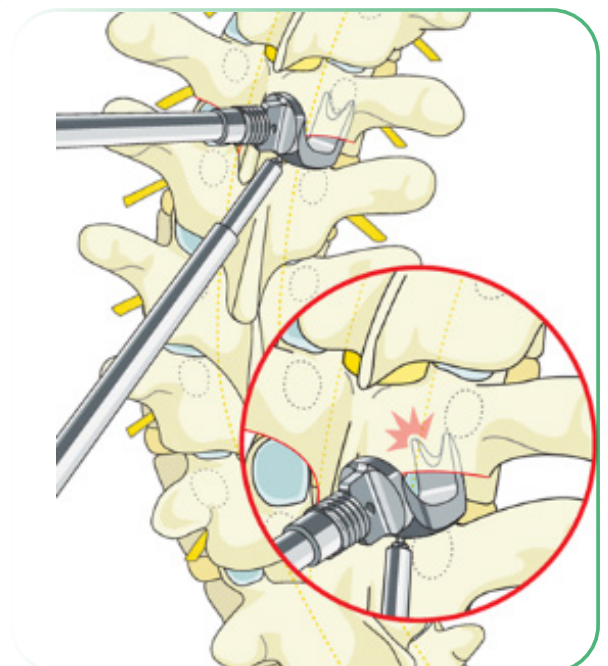

Figure 5

SURGICAL PROCEDURE LAMINAR HOOKS

Usually, Laminar Hooks are introduced by removing an appropriate amount of ligamentum flavum and surrounding bone to provide safe introduction of the Hook into the spinal canal in an infralaminar (up-going) or supralaminar (down-going) position depending upon on the appropriate level of vertebrae. (Figure 6)

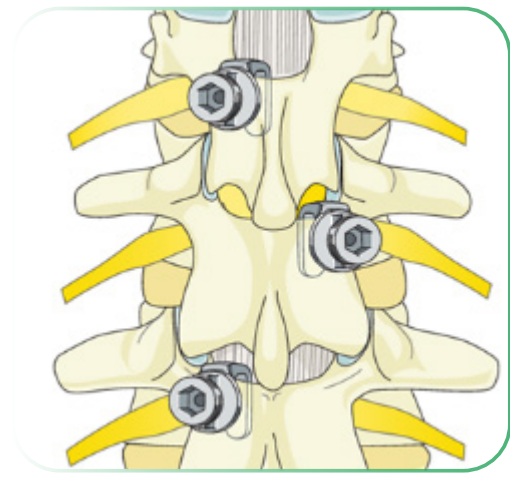
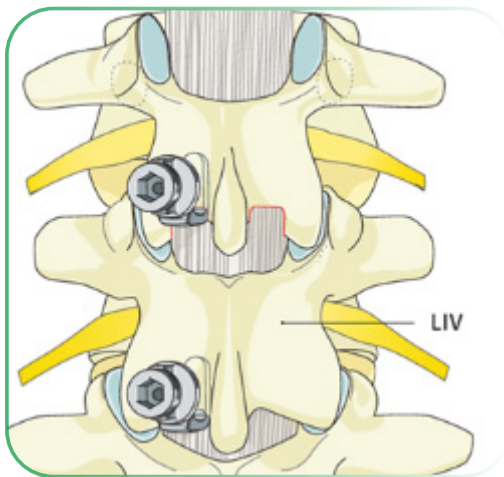

Figure 6

Step 1 Surgical Preparation

The patient is usually positioned prone on a spinal table. The general essentials of posterior spinal fusion surgery are applied. (Figure 7)



Figure 7

Step 2 Hook Side Preparation

The Hook Lamina Elevator (PH 500.10.003) can be used to separate the ligamentum flavum from the lamina before implant insertion to ensure good bony contact with the hook. (Figure 8).

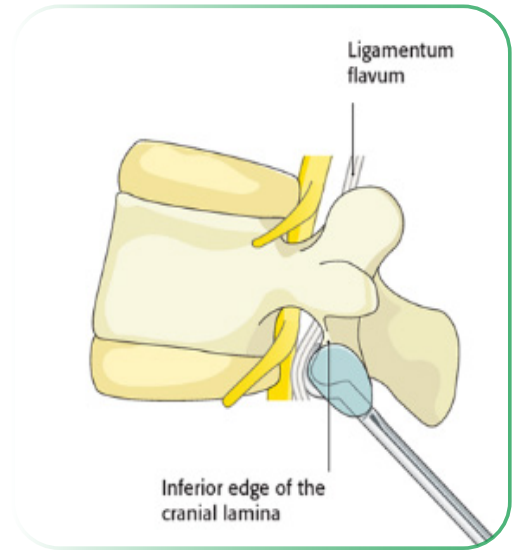

Figure 8

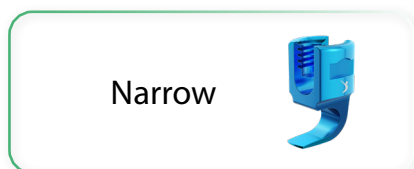

Figure 9

Step 3 Laminar Hooks Insertion

Once the lamina is confirmed to be well prepared, the appropriate-sized laminar hook is introduced with Hook Inserter 1 (PH 500.10.001) and placed in the required position with help of Hook Inserter 2 (PH 500.10.002) to facilitate the placement. (Figure 9)

The widest hook possible should be selected to distribute load and maximize the bone/implant junction. The hook should have a snug fit around the lamina with no space between the bone and hook therefore it cannot advance further into the spinal canal. If any space remains, the hook should be replaced with a narrow bladed hook. To verify the hook integrity, the surgeon can pull up on the hook using the inserter; an appropriately sized and positioned hook will pull the vertebra up with this movement. (Figure 10)



Narrow

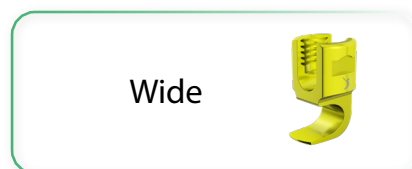

Wide

Figure 10

Step 4 Selection of the Appropriate Size of Rod

After the hooks are placed, the appropriate rod length should be selected for the related levels. It's recommended to position the tips of the rod to be extended around 1-2 mm out from the first and last hooks placed.

Step 5 Rod Bending

Then the rod is placed on the rod bender and it's bended as needed. A properly contoured rod should contact the bottom of each hook's saddle. (Figure 10)

Note: You can switch the bending angles by pulling and rotating the central wheel of the rod bender, thus you can bend the rods through small, medium, and large angles. (Figure 10)

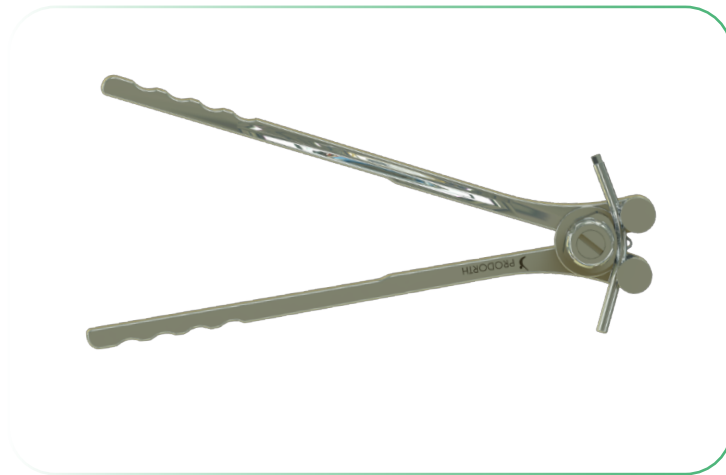
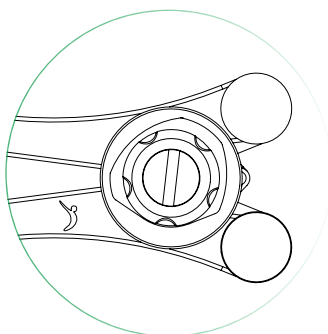
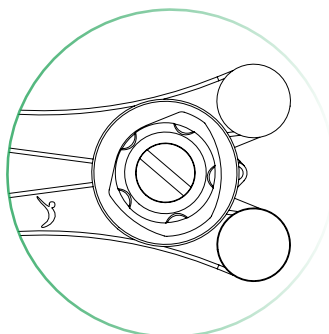

Figure 10



Small



Medium

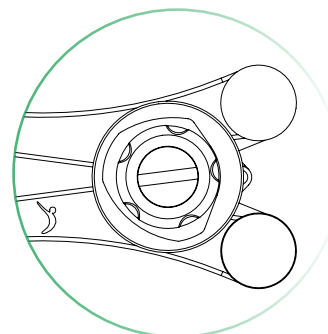

Large

After the hooks are placed and the rod is contoured as required, the rod is placed into the hook saddle by the FORCEPS HOOK HOLDER (Upon Request - PH 500.10.009) as represented in the picture. (Figure 11)

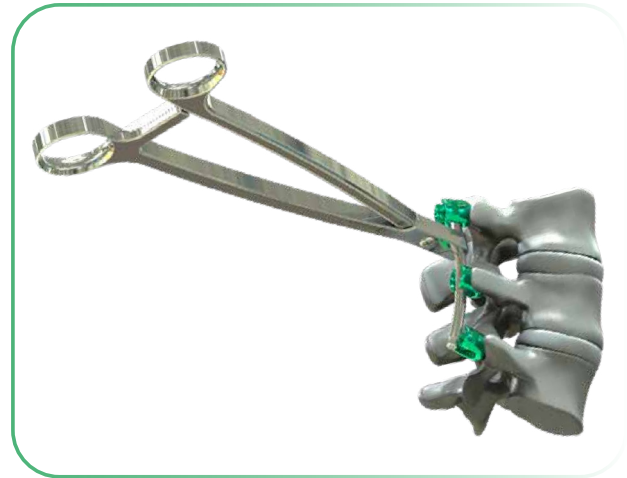

Figure 11

Step 6 Insertion of Setscrews

The setscrews will be priorly introduced into the saddle of hooks with Slitted Setscrew Inserter (PP 100.10.020 / Provided within Posterior Fixation System Instrumentation or can be provided individually upon request).

Warning: The “Slitted Setscrew Inserter” is not an instrument for tightening but only for the initial introduction of the setscrews. Since it has a slit on its shaft, the setscrew can be attached easily and inserted smoothly without using bone wax.

Warning: Please pay attention while introducing the setscrews, If some resistance is felt during the introduction of the setscrew, verify that it is not cross-threaded.

Once you ensure the setscrew is seated properly into the saddle of the hook keep rotating the setscrew driver to advance the setscrew to the bottom of the saddle.

Repeat the process until all setscrews are placed.

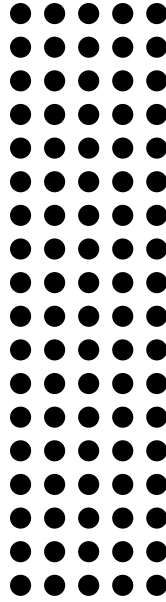

Surgical Technique Guide

HOOK FIXATION SYSTEM



See the IFU prior to use for additional information.



Please check our website for the latest version of this Surgical Technique.



2292



TD.03.06.03 / Rev.05 / 25.07.2022

info@prodorth.com



0090 2323 48 49 50 (pbx)



Karacaođlan Mah. Bornova Cad.
Öztim İş Merkezi No:9/G/1
Bornova - İzmir / TURKEY

